

## Installation, Operating, and Maintenance Instructions

### Underrun Protection, Type: WUF 105 K

## Assembly:

### Assembly plate:

The left and right assembly plates are screwed onto the side of the vehicle frame via the designated bore holes. The following items shall be used per side for this purpose:

min. 4 x M16 hexagonal screws - DIN EN ISO 4017, strength class 10.9, MA=290 Nm

min. 4 x M16x1,5 hexagonal screws - DIN EN ISO 8676, strength class 10.9, MA=310 Nm

min. 4 x M16x1,5 flange screw - DIN 6921, strength class 10.9, MA=250+10 Nm

min. 6 x M16 countersunk-head screw - ISO 10642, strength class 10.9, MA=290 Nm

min. 6 x M14 hexagonal screws - DIN EN ISO 4017, strength class 10.9, MA=185 Nm

min. 6 x M14x1,5 hexagonal screws - DIN EN ISO 8676, strength class 10.9, MA=200 Nm

min. 6 x M14x1,5 flange screw - DIN 6921, strength class 10.9, MA=160+10 Nm

### Support arm:

The left and right support arms are pushed onto the bolts belonging to the assembly plate and are secured via a M24x1.5 nut - DIN 980 with an A25 washer or, optionally, a B25 - DIN 125 washer. The nut shall be tightened hand-tight and without clearance.

### Gas spring:

The gas spring (optionally 2 or 0) is pushed onto the bolts attached to the support arm and the threaded bolt that is screwed into the assembly plate and is secured with the SL locking devices. The support arm is in the folded up position. The piston rod belonging to the gas spring points to the rear in the direction of travel.

Attention! The gas spring, and the piston rod in particular, may not be painted.

### Operation:

The cross pipe can be pivoted up or down by loosening the spring latch. The spring latch must be re-engaged following the adjustment process.

### Servicing:

All screw connections must be tested every 3 months to ensure that they are firmly seated. If necessary, they must be re-tightened with the stipulated torques. The bearing and the spring latch must be greased via the lubrication nipples at appropriate intervals.

Nummer		Datum	Name
MA-084-GB	Bearb.	12.12.2013	Bock

## Installation, Operating, and Maintenance Instructions

### Underrun Protection, Type: WUF 105 K

#### Clamped cross pipe (design A)

The cross pipe is pushed through the clamping brackets of the support arms and is symmetrically clamped by tightening the screws.

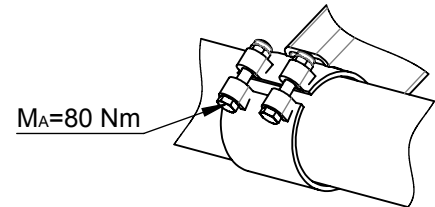

#### Clamped cross pipe (design A1, D)

The cross pipe is placed into the opening of the support arms and it is secured against shifting with the bracket. The bracket is fixed into place using 2 M12 screws on the top and 2 M12 screws on the bottom.

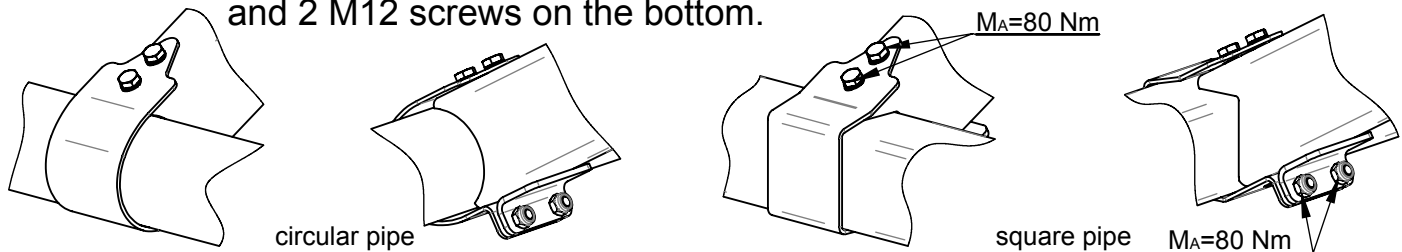

#### Clamped cross pipe (design A4)

The cross pipe is placed into the opening of the support arms. As a result, the bracket is pushed onto the pipe in such a manner that the lower strap of the bracket reaches into the support arm. The clamping sheet is now inserted from above via the slot in the support arm and the bracket. The bracket must be screwed to the clamping sheet in such a manner that a shifting of the cross pipe is prevented.

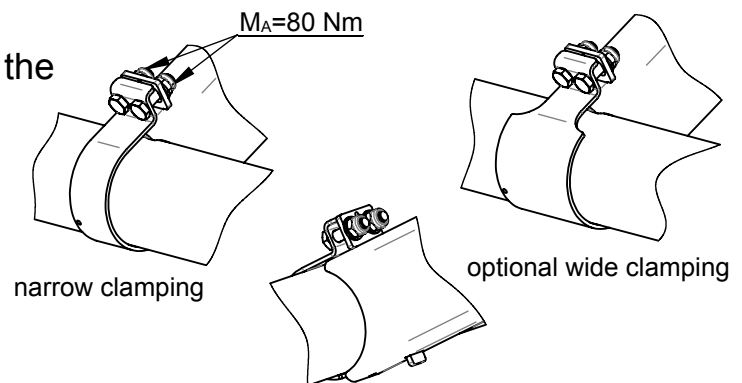

#### Welded cross pipe (design A2, A3)

The cross pipe is symmetrically welded in the positive openings of the support arms with circumferential a 4,2 fillet welds.

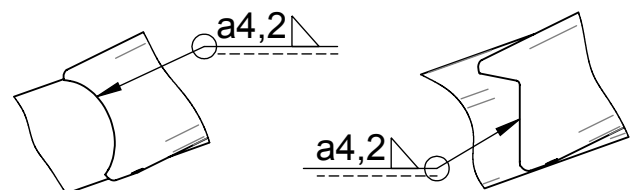

#### Bolted underride guard (design B, C)

On each side, the underride guard is screwed onto the support arm plates with 2 hexagonal screws and hexagonal nuts respectively. Min. screw size M10 - 8.8, max. M16 - 10.9.

MA (with M10)=46 Nm.

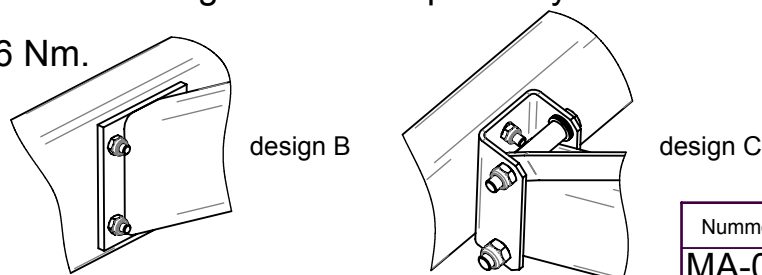

Nummer		Datum	Name
MA-084-GB	Bearb.	12.12.2013	Bock

Installation, Operating, and Maintenance Instructions  
Underrun Protection, Type: WUF 105 K

Clamped cross pipe design A

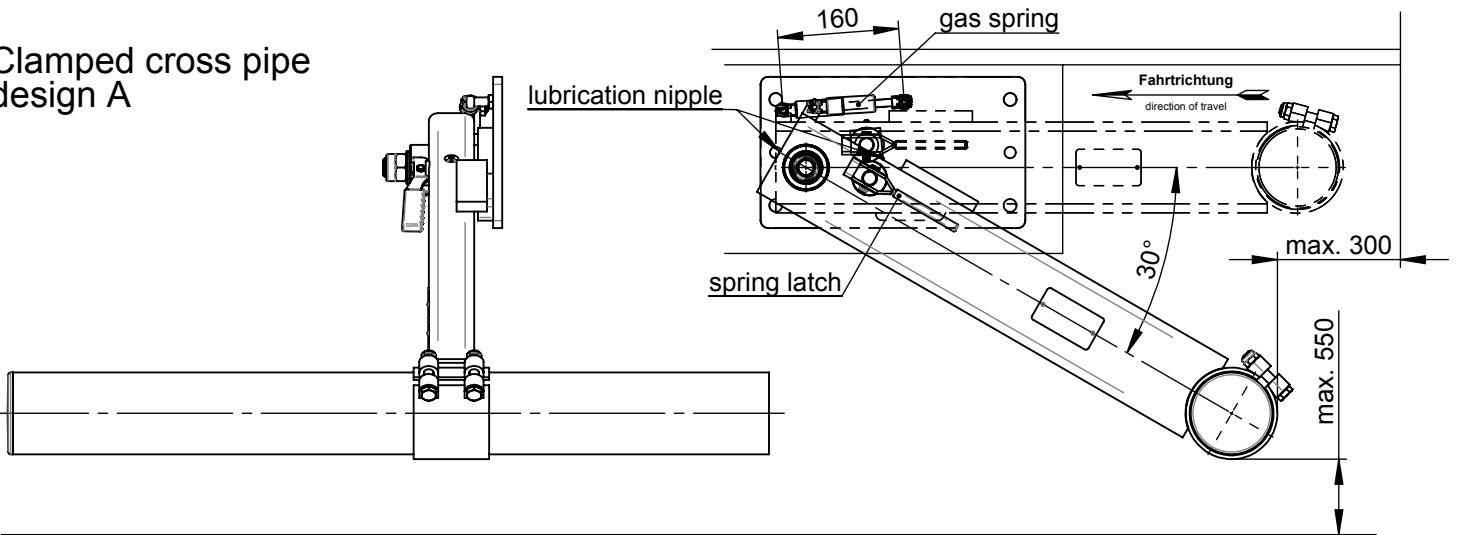

Clamped cross pipe design A1

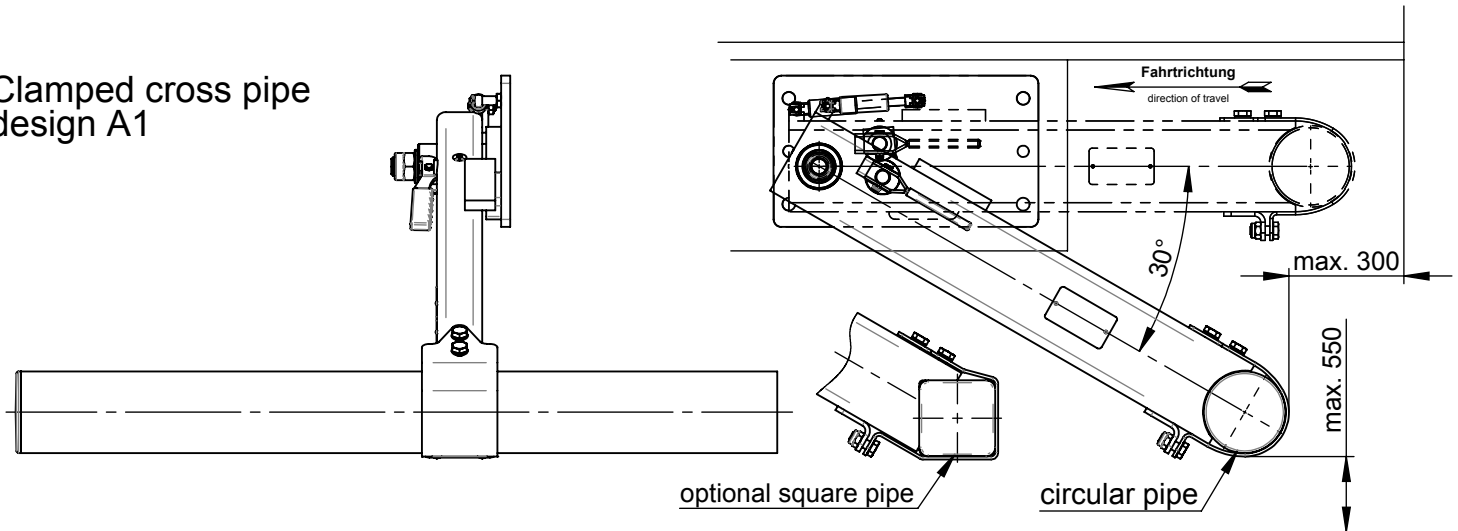

Welded cross pipe design A2 und A3

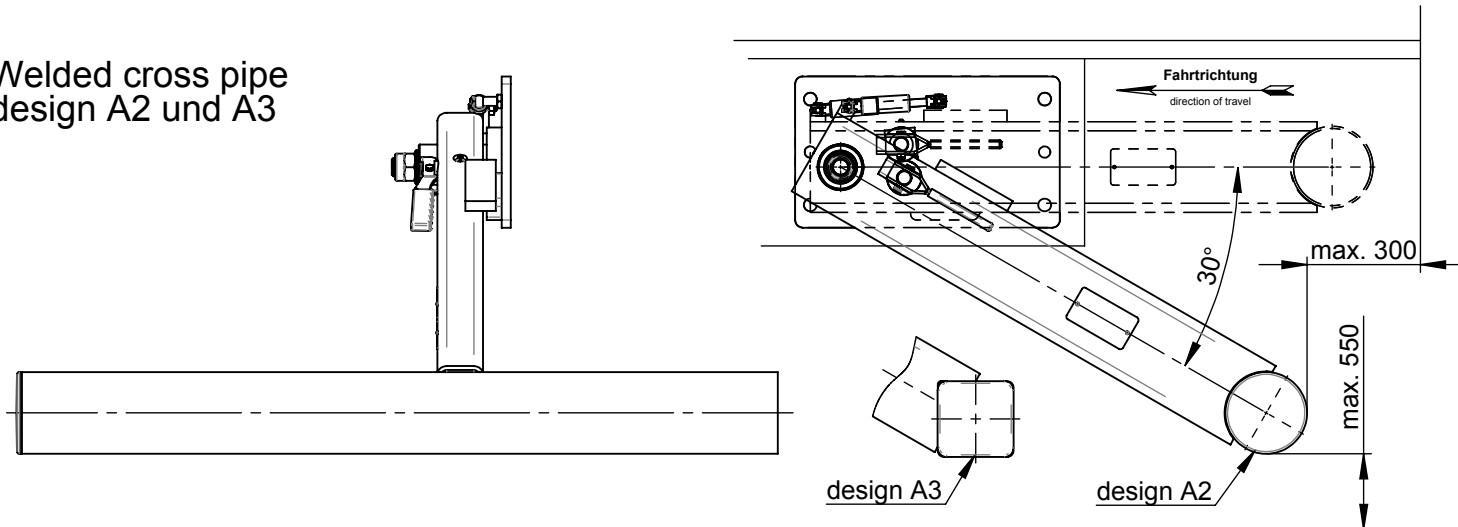

Nummer		Datum	Name
MA-084-GB	Bearb.	12.12.2013	Bock

Installation, Operating, and Maintenance Instructions  
Underrun Protection, Type: WUF 105 K

Clamped cross pipe design A4

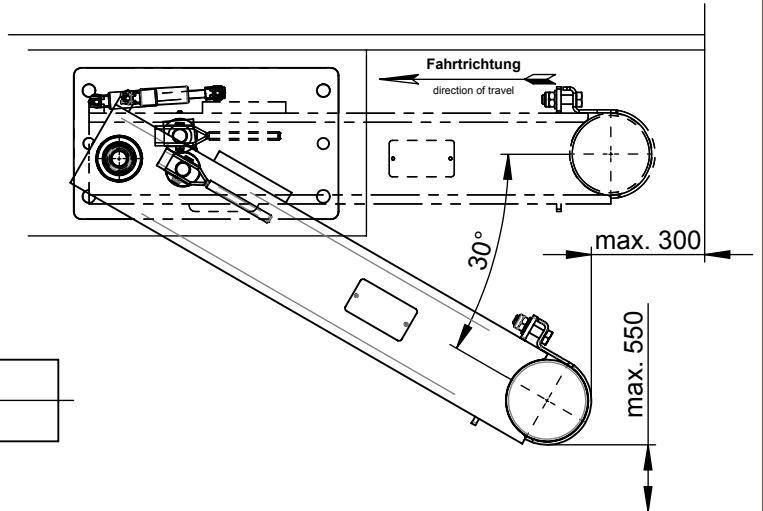
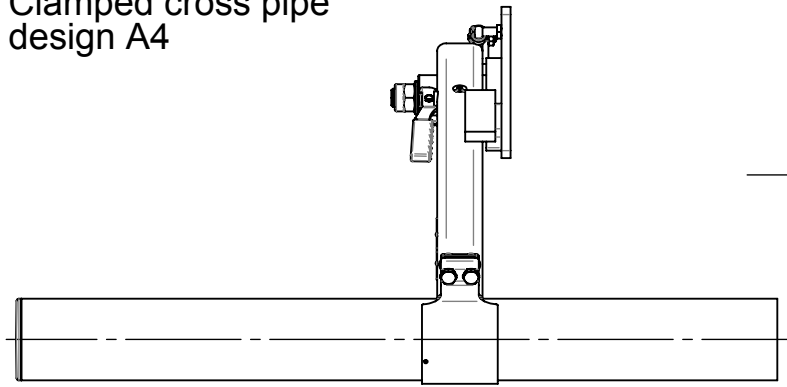

Bolted underride guard design B

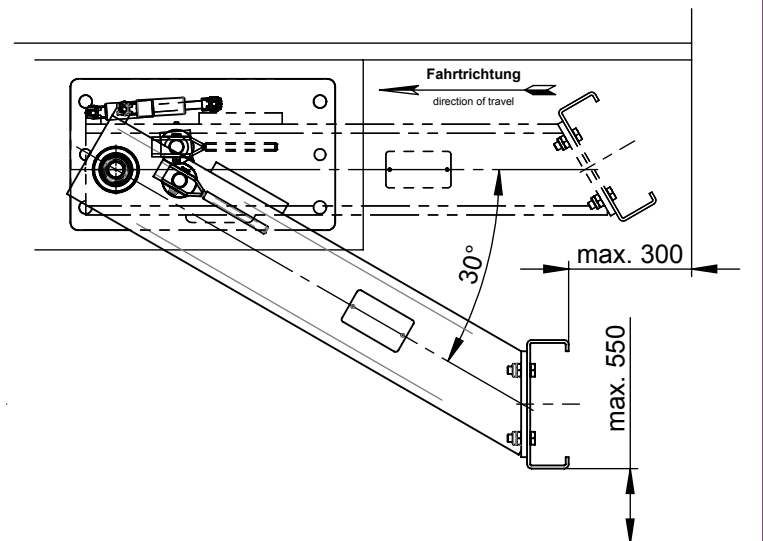
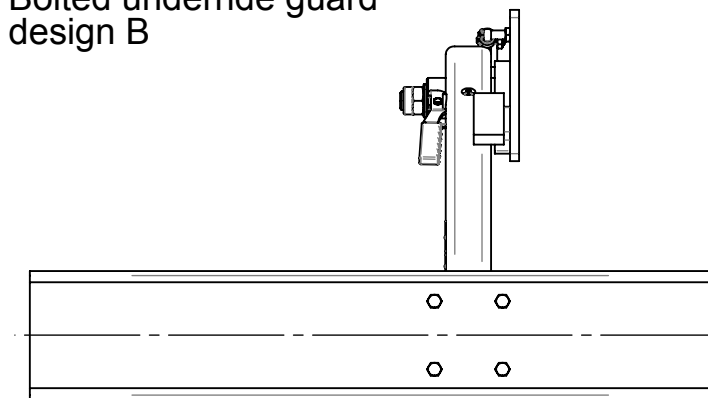

Bolted underride guard design C

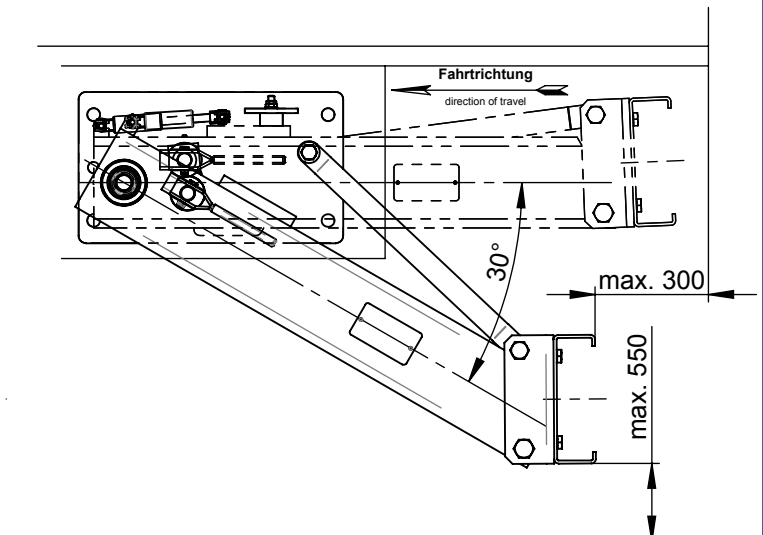
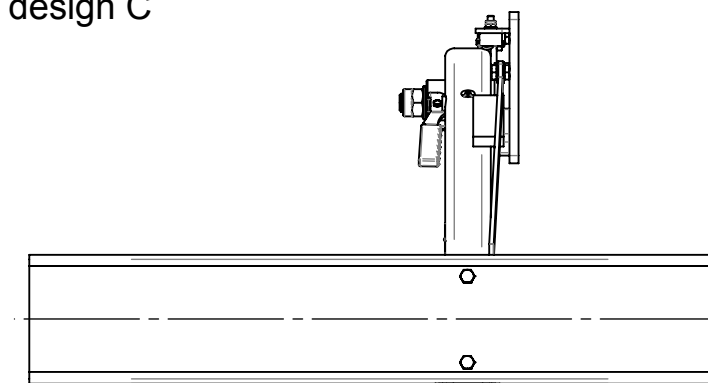

Nummer		Datum	Name
MA-084-GB	Bearb.	12.12.2013	Bock

Installation, Operating, and Maintenance Instructions  
Underrun Protection, Type: WUF 105 K

Clamped cross pipe design D

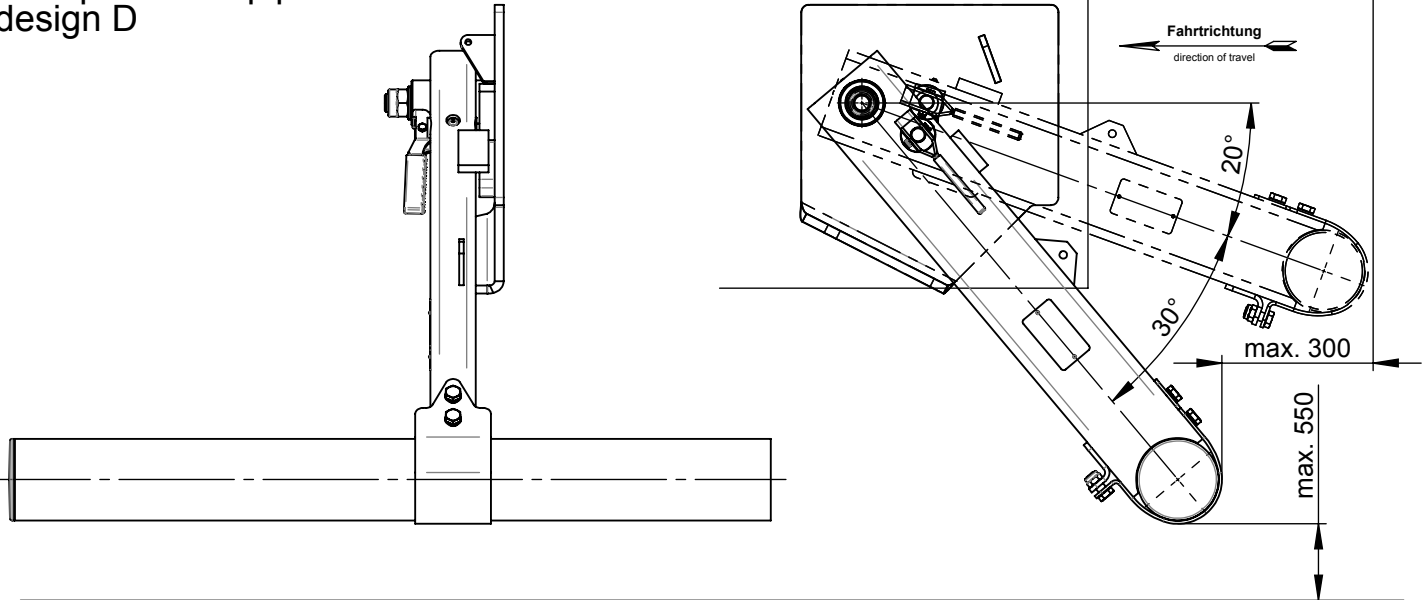

Underride guard with welding sheets

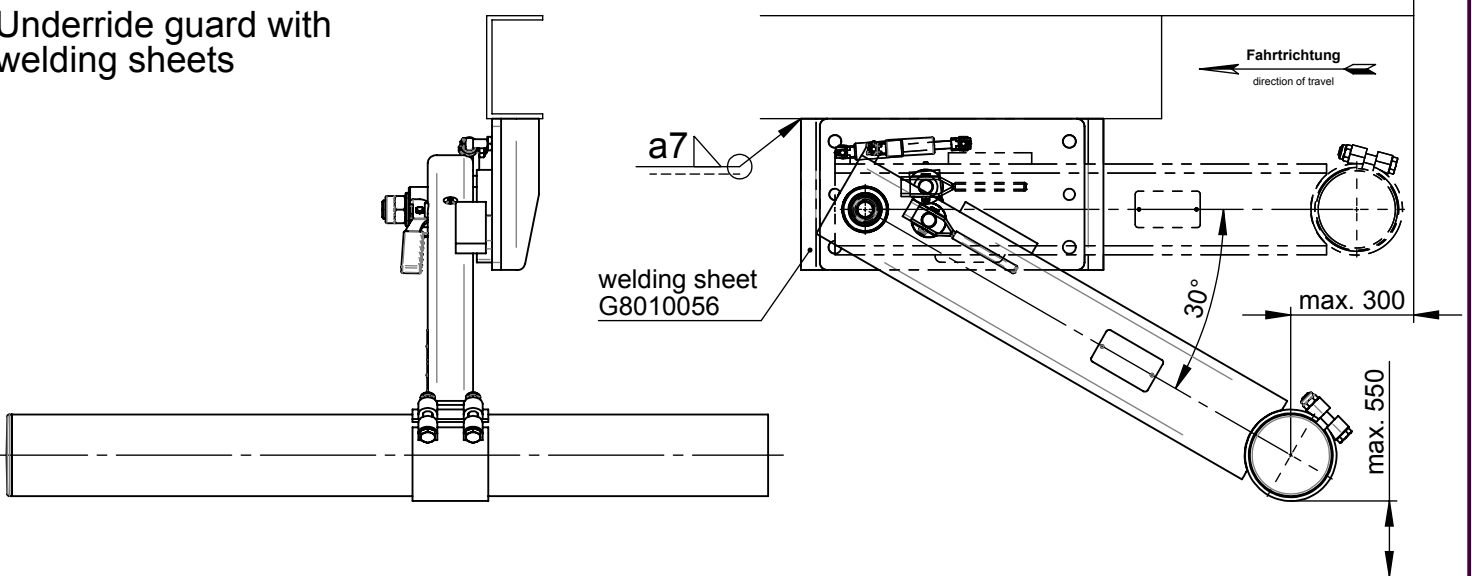

Nummer		Datum	Name
MA-084-GB	Bearb.	12.12.2013	Bock

**Installation, Operating, and Maintenance Instructions**  
**Underrun Protection, Type: WUF 105 K**

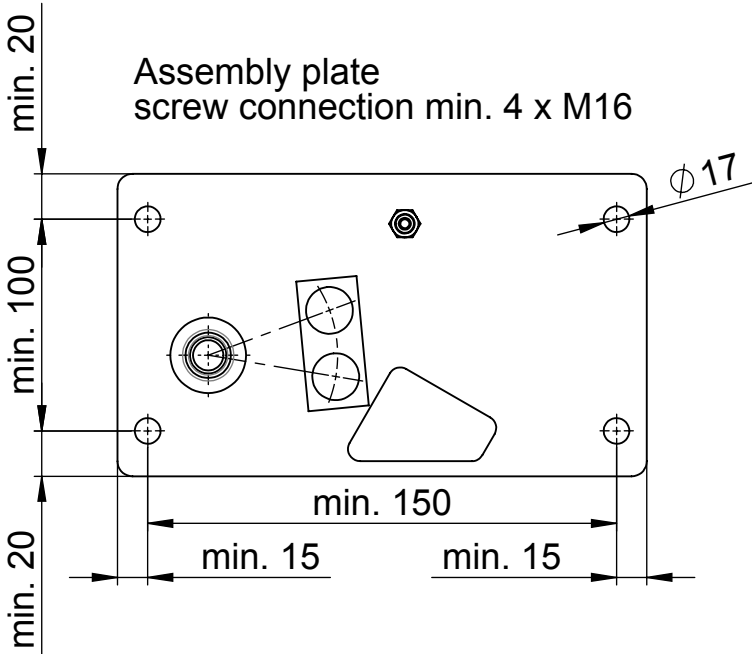

optional design

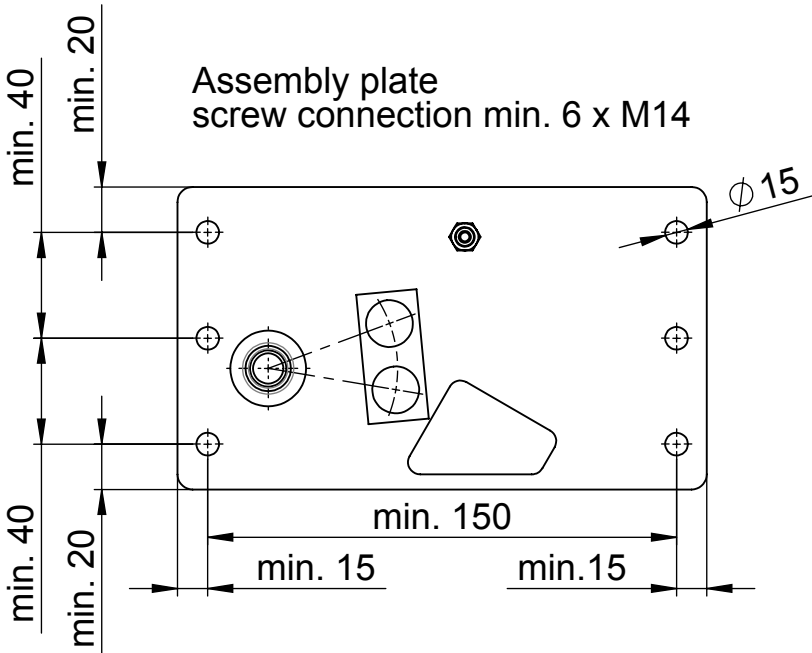
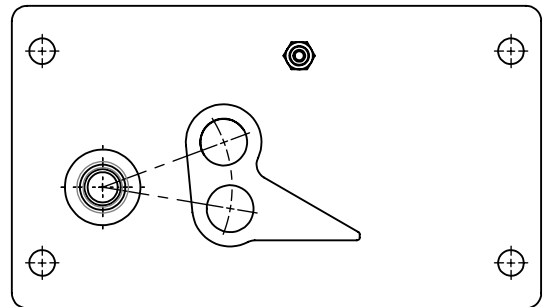

optional design

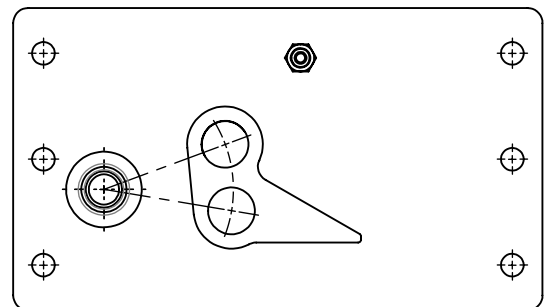

The potential bore pattern must be inspected and approved by the manufacturer.

Nummer		Datum	Name
MA-084-GB	Bearb.	12.12.2013	Bock

Installation, Operating, and Maintenance Instructions  
Underrun Protection, Type: WUF 105 K

Cross pipe variants

Ø108 circular pipe

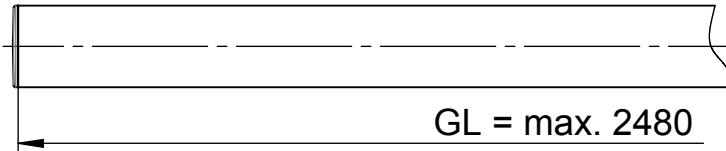
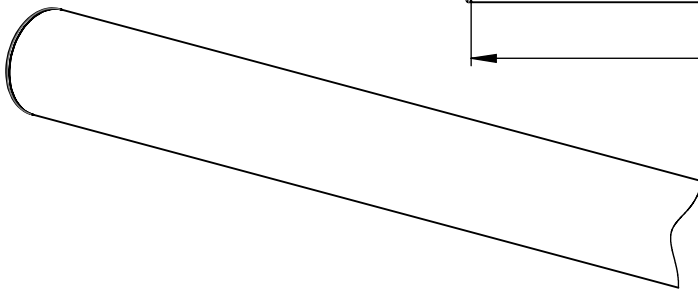

GL = max. 2480

(standard = 2350)

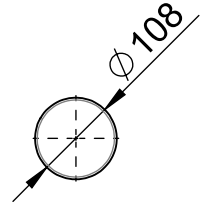

square pipe □ 100

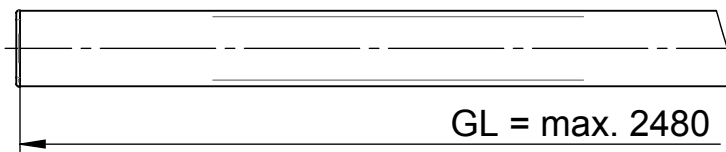
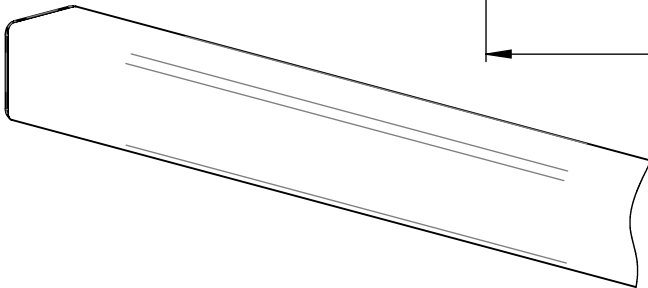

GL = max. 2480

(standard = 2350)

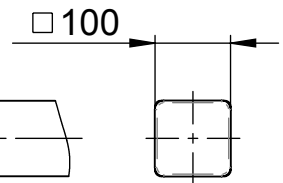

Ø108 circular pipe,  
divided

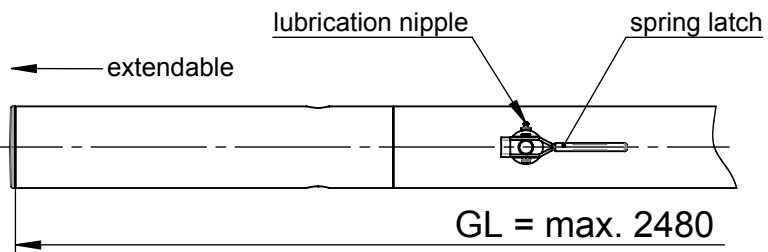
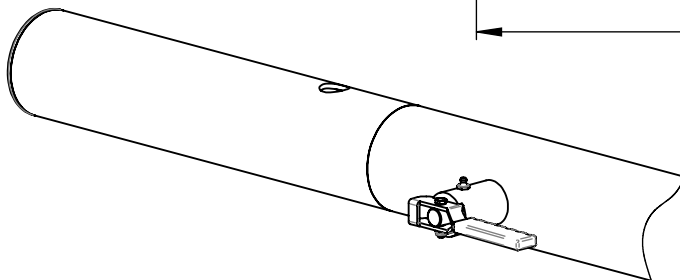

GL = max. 2480

(standard = 2350)

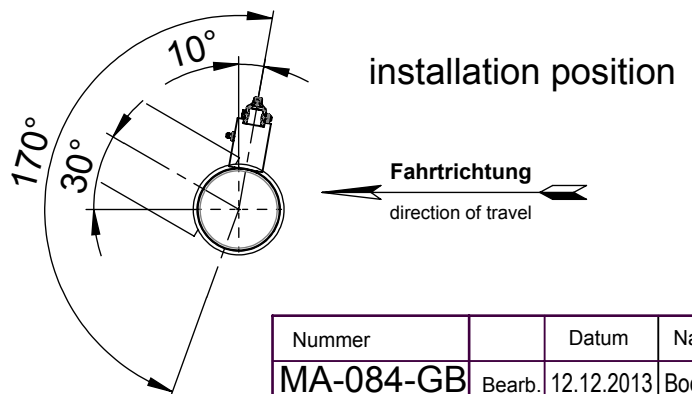
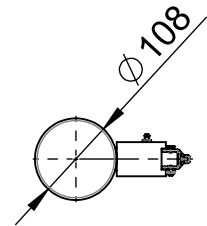

Nummer		Datum	Name
MA-084-GB	Bearb.	12.12.2013	Bock

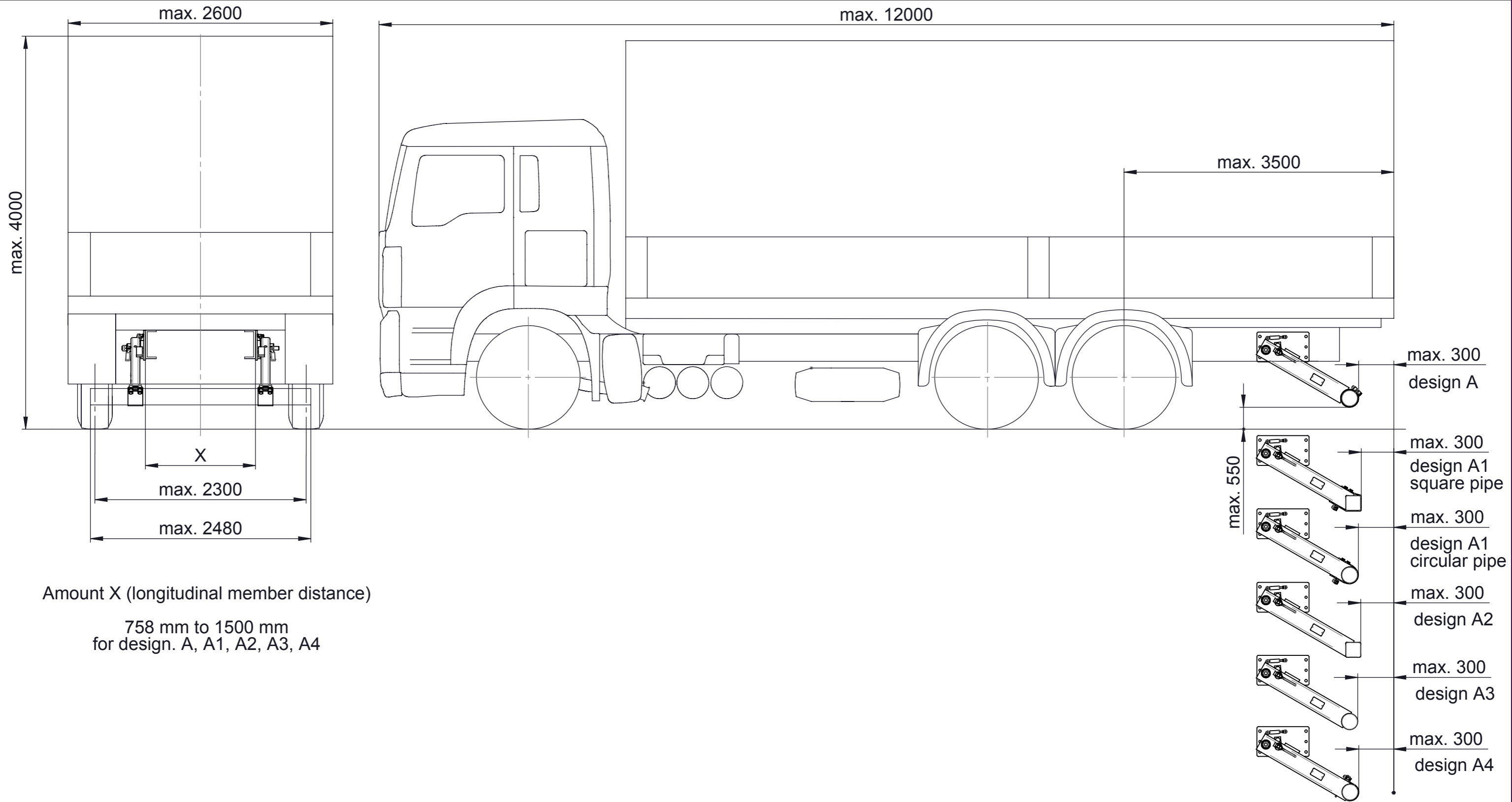

Amount X (longitudinal member distance)

758 mm to 1500 mm  
for design. A, A1, A2, A3, A4

				Oberfläche nach DIN ISO 1302			Werkstoff / Bemerkung 8 / 9		
				Zul. Abweichungen für Maße ohne Toleranzangabe ISO 2768 -c					
				Datum	Name	Maßstab	Benennung		
				Bearb. 25.04.2012	Schneider	-	<b>Installation</b> WUF 105 K Ausf. A, A1, A2, A3, A4		
				Oberfläche [cm <sup>2</sup> ]		Gewicht* [kg]			
Zust.	Änderung	Datum	Name	-				Zeichnungsnummer	
								<b>MA-084-GB</b>	
								Ersatz für <span style="float: right;">Vorgang:</span>	
Für diese Zeichnung behalten wir uns alle Rechte vor. Ohne unsere vorherige Zustimmung darf sie weder vervielfältigt noch Dritten zu gänglich gemacht werden, und sie darf durch den Empfänger oder Dritte auch nicht in anderer Weise miß-bräuchlich verwendet werden.				 <b>Fahrzeugtechnik GmbH</b>		<b>A3</b>			

\* Theoretisches Gewicht ! Schweißnähte, Farbe und Betriebsmittel sind nicht berücksichtigt !



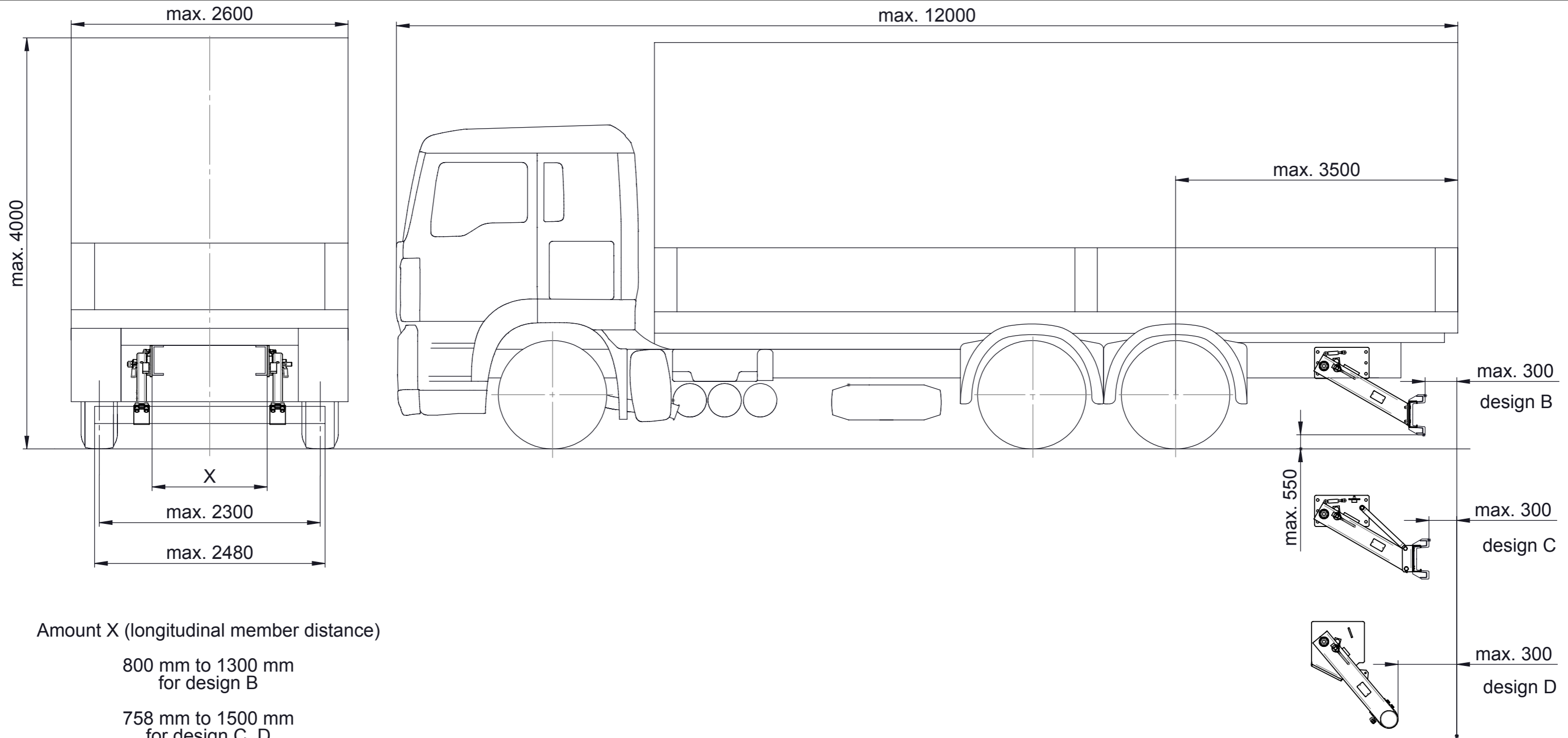

Amount X (longitudinal member distance)

800 mm to 1300 mm  
for design B

758 mm to 1500 mm  
for design C, D

				Oberfläche nach DIN ISO 1302			Werkstoff / Bemerkung Seite 9 von 9	
				Zul. Abweichungen für Maße ohne Toleranzangabe ISO 2768 -c				
				Datum	Name	Maßstab	Benennung	
				Bearb. 25.04.2012	Schneider	-	<b>Installation</b> WUF 105 K Ausf. B, C, D	
				Oberfläche [cm²]		Gewicht* [kg]		
Zust.	Änderung	Datum	Name	-				Zeichnungsnummer
								<b>MA-084-GB</b>
								<b>A3</b>
								Ersatz für
								Vorgang:

\* Theoretisches Gewicht ! Schweißnähte, Farbe und Betriebsmittel sind nicht berücksichtigt !